

## MC034S Two-output Occupancy Sensor



### Introduction

- Two individual controls for lighting and ventilator, applicable to bathroom.
- Advanced microwave technology, can detect slight motions.
- independent sensor for flush mounting and concealed installation
- Zero-crossing point operation helps protect the sensor against in-rush current.
- Detection area, hold time and daylight threshold can be precisely set by DIP switch.

MC034S is an innovative and active motion detector with HF system 5.8GHz. It is always functioning regardless of the background temperature.

It supplies individual two outputs to control different loads, suitable for bathroom or any other place where requires different ON-OFF control.

Three torsion springs support flush mounting and concealed installation.



Max.5M



Slight Motion Detection



Hold Time  
5s~10min(CH1)  
5s~20min(CH2)

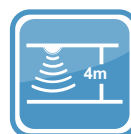

Mounting Height  
4m Max.



5 Years  
Guarantee

## Function

### ON-OFF function

Typical use for MC034S is to install it in bathroom. Two output channels can separately control LED light and ventilator.

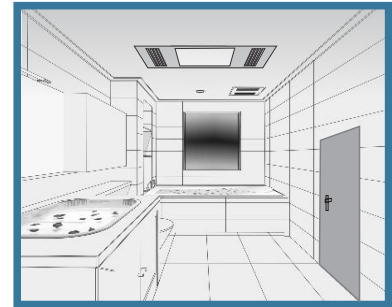
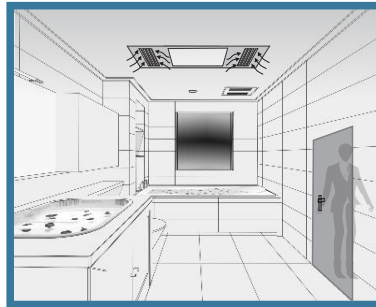
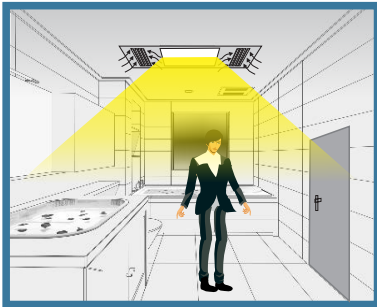

Motion detected, light and ventilator turn on.

The light turns off when no person in bathroom. Ventilator stops after elapse of hold time.

#### How to install?

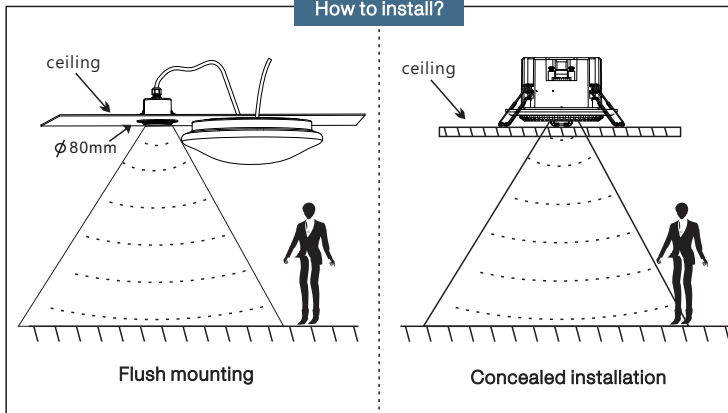

#### Wiring scheme

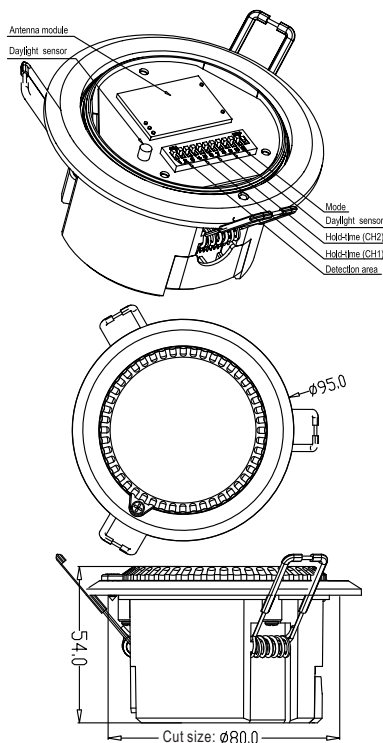
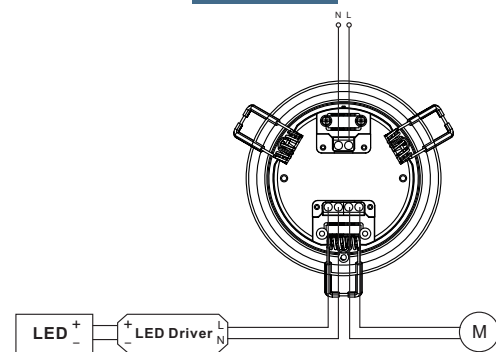

## MC034S

Operating voltage	220~240Vac, 50Hz/60Hz
Rated load	200W(Inductive), 400W(Resistive)
HF system	5.8GHz±75MHz, ISM wave band
Transmitting power	<0.5mW
Power consumption	≤0.8W(standby), <1.5W(operation)
Detection zone	Max.(D x H): 10m x 4m
Mode	High / Nomal
Hold time	Ch1: 5s / 90s /3min /10min/ Ch2: 5s/5min/10min/20min
Daylight sensor	5lux / 15lux / 50lux / Disable
Cut size	80mm
Mounting height	4m Max.
Motion detection	0.5~3m/s
Detection angle	150°(wall installation), 360°(ceiling installation)
Operating temperature	-35°C~60°C
IP rating	IP20

## Detection Pattern

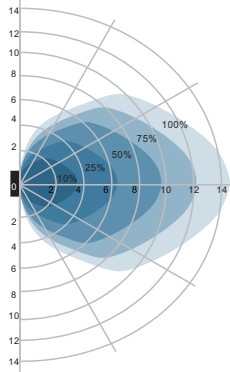

Wall mounting pattern (Unit: m)  
Suggested installation height: 1-1.8m

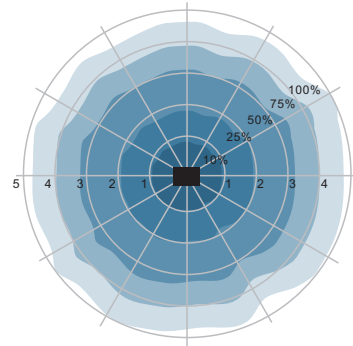

Ceiling mounting pattern (Unit: m)  
Suggested installation height: 2.5-4m

## Setting

By selecting the combination on the DIP switch, sensor data can be precisely set for each specific application.

ON ↑ [DIP Switch]		1	2	3	
	I	ON	ON	ON	100%
	II	-	ON	ON	75%
	III	ON	-	ON	50%
IV	ON	ON	-	25%	

### Detection area

Detection area can be reduced by selecting the combination on the DIP switches to fit precisely each application.

ON ↑ [DIP Switch]		4	5	
	I	ON	ON	5s
	II	ON	-	90s
	III	-	ON	3min
IV	-	-	10min	

### Hold time (CH 1)

Refers to the time period the lamp remains at 100% illumination after no motion detected.

ON ↑ [DIP Switch]		6	7	
	I	ON	ON	5s
	II	ON	-	5min
	III	-	ON	10min
IV	-	-	20min	

### Hold time (CH 2)

Refers to the period the ventilator remains running.

ON ↑ [DIP Switch]		8	9	10	
	I	ON	ON	ON	Disable
	II	-	ON	-	50lux
	III	ON	-	-	15lux
IV	-	-	-	5lux	

### Daylight sensor

The sensor can be set to only allow the lamp to illuminate below a defined ambient brightness threshold.

When set to Disable mode, lamp will be switched on when motion is detected regardless of ambient light level.

50lux: twilight operation, 15lux, 5lux: darkness operation only.

Note that daylight sensor is active only when lamp totally switches off.

ON ↑ [DIP Switch]		11	
	I	ON	High
II	-	Normal	

### Mode

**Highly Sensitive Mode**

Motion sensor works in a highly sensitive mode, can detect slight movements, for example, washing hands, move finger and so on.

**Normal working mode**

Motion sensor works in a normal working mode, can detect obvious movements, for example, walking, raise your arms, jump up, sit down, and shake your body.